



Bryan-Dumon™ Series II Rigid Bronchoscope and Stent Placement Kit

USER MANUAL



TABLE OF CONTENTS

BRYAN-DUMON™ SERIES II RIGID BRONCHOSCOPE

- 1. Diagram and Overview**
- 2. Universal Barrel**
- 3. Bronchial and Tracheal Tubes**
- 4. Accessory Ports**
- 5. Telescope, Camera and Light Source**

BRYAN-DUMON™ SERIES II STENT PLACEMENT KIT

- 1. Inspection and Overview**
- 2. Stent Loading**
- 3. Stent Deployment**
- 4. Y-Stent Loading and Deployment**

DISINFECTING AND STERILIZING THE INSTRUMENTS

- 1. Disinfection and cleaning of the Bronchoscope**
- 2. Disinfection and cleaning of the Telescope**
- 3. Gas Sterilization**
- 4. Steam Sterilization**
- 5. Contact**



BRYAN-DUMON™ SERIES II RIGID BRONCHOSCOPE-DIAGRAM

- Check that your instrument is in good condition and that the tubes are neither damaged nor obstructed.
- If you have purchased telescopes with the system, look through the telescopes to confirm the lenses are in good condition.

***PICTURES ARE NOT TO SCALE**

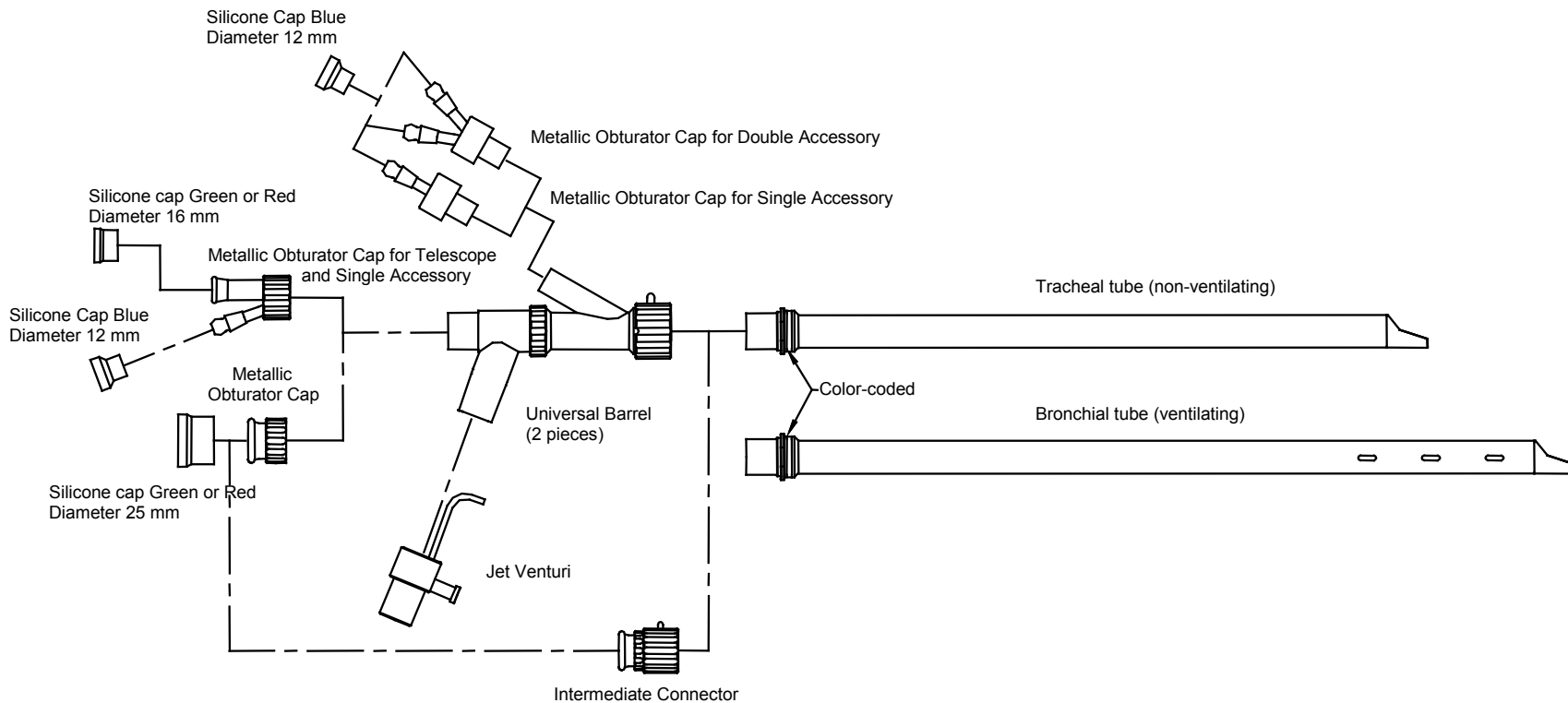

UNIVERSAL BARREL

- Make sure that the ribbed rings on the universal barrel rotate, the small ring 360° and the large 90°.
- Connect the two pieces of the barrel together.
- The universal barrel has two lateral ports and one main horizontal port.
- Connect the metallic obturator cap to the main port. (In addition, there is an obturator cap for telescope and single accessory that can be used when the flexible bronchoscope is introduced through the rigid).
- The larger lateral port may be used for ventilation and anesthesia. Connect the jet venturi or place a silicone cap over the access port if it is not being used.
- The smaller lateral port is for accessories. You may connect the metallic obturator caps for single or double accessory to the smaller port.

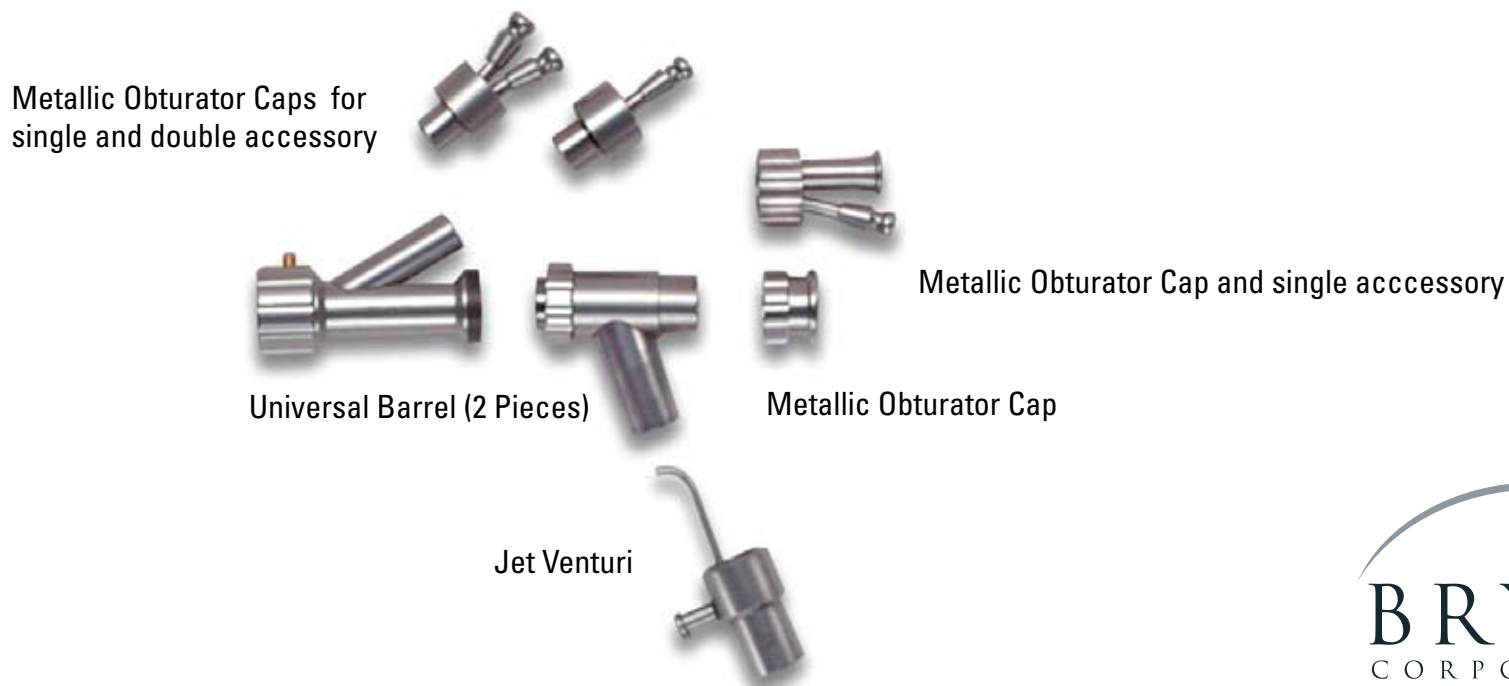

TRACHEAL AND BRONCHIAL TUBES

- Select the desired size tracheal or bronchial tube. All tubes are color-coded, indicating different tube diameters. The tube diameter (in millimeters) is etched on the tube directly below the color-coded ring.
- Introduce the selected tube to the airtight lock back of the universal barrel by aligning the red dots. Lock the tube to the universal barrel by turning the rotating ring a quarter turn to the right.

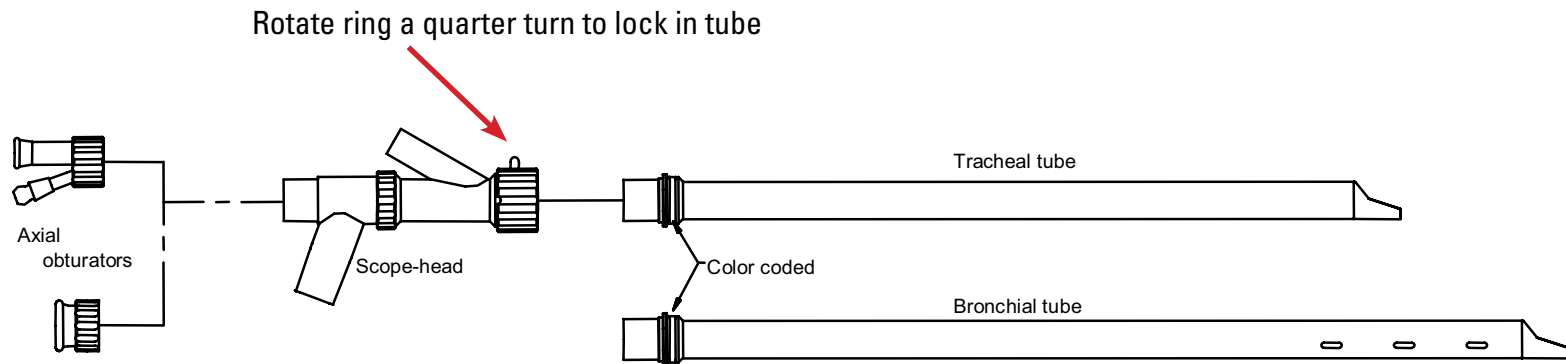

SIDE PORTS

- Select the metallic obturator cap for either single or double accessory to go into the lateral port of the universal barrel. Connect the desired obturator cap to the side port by pushing and turning it.
- Connect the jet venturi (if used) to the larger diameter lateral port of the universal barrel.
- If closed system is used, select the appropriate silicone caps according to your instrument configuration (optics, suction catheter, laser fibers, etc.). Connect the silicone caps to the metallic ports as shown below.

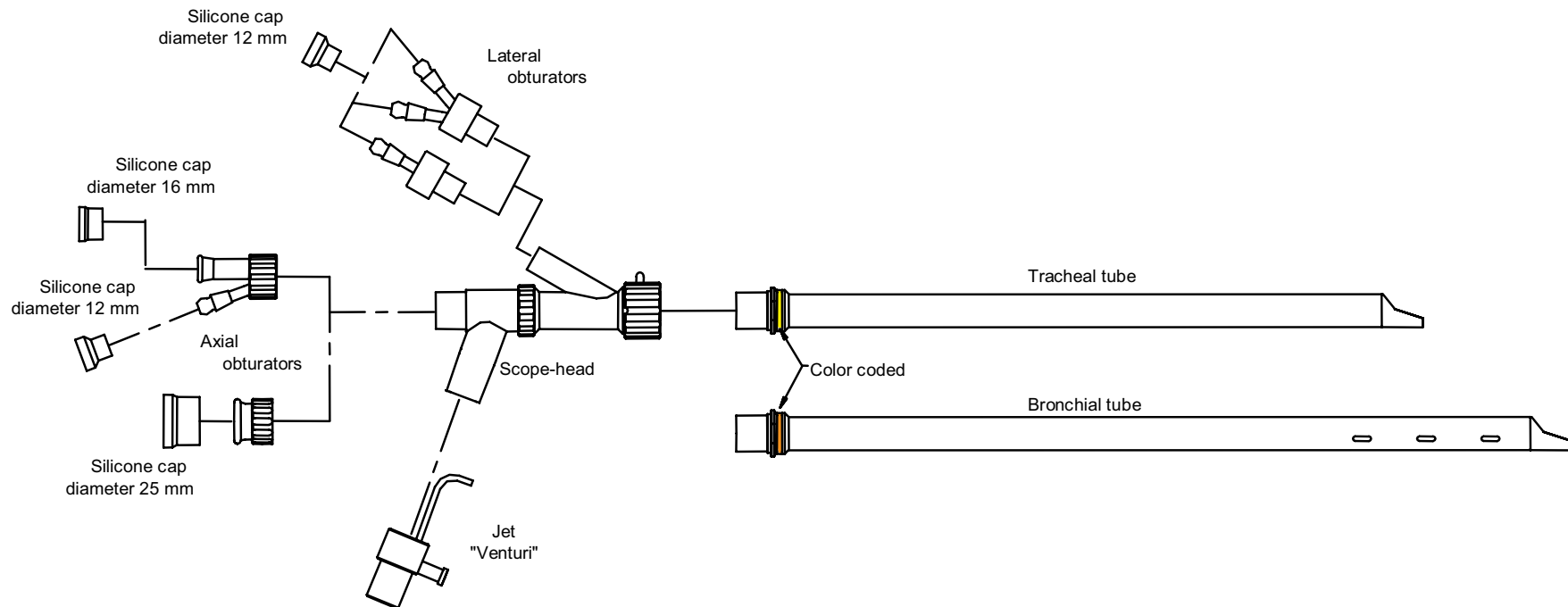

TELESCOPE, CAMERA AND LIGHT SOURCE

- Insert the telescope into the bronchoscope through the hole in the silicone cap. The red caps are for the 5.5 mm telescope and the green caps are for the 4.0 mm telescope. If you are using open system ventilation, it is not necessary to use the caps.
- Connect the camera and light cable to the telescope.
- Telescope has three different light cable adapters: STORZ/Olympus, WOLF and ACMI (see picture below).
- Telescope eyepiece fits a universal C-mount camera.

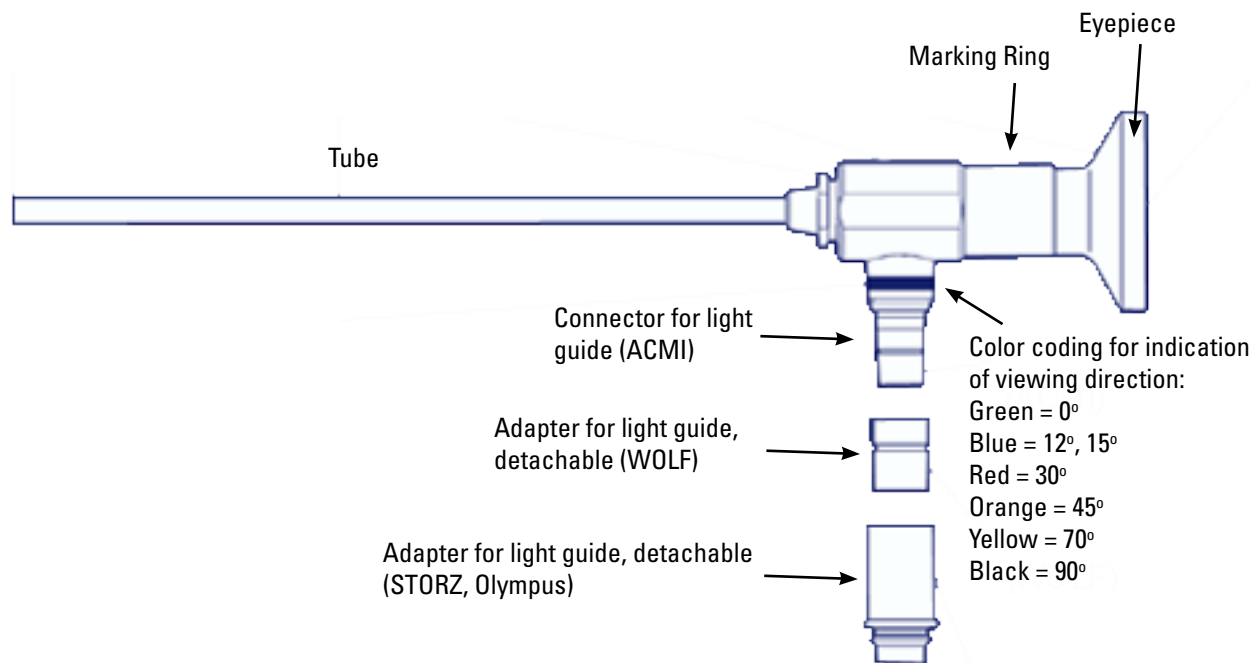

STENT PLACEMENT KIT

- The Bryan-Dumon™ Stent Placement Kit is specially designed for deploying the Dumon Style silicone stents.
- The basic stent placement kit consists of three parts- stent introducer tube, stent plunger and stent funnel.
- Stent placement kits are color-coded to correspond with the tracheal and bronchial tubes.
- The recommended stent sizes for each kit are etched on each introducer tube. (Please note, the orange stent introducer can accommodate large stents up to 22 mm in addition to all Y-stents).

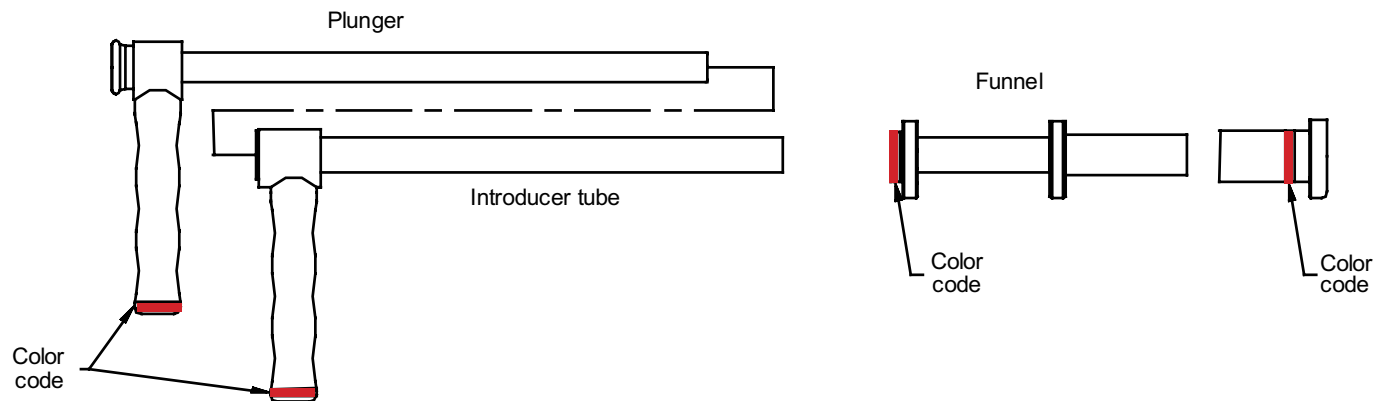

STENT PLACEMENT KIT - GETTING STARTED

- Check that your instrument is in good condition by inspecting the tubes for damage or obstruction. Make sure the handles of the introducer tube rotates 360 degrees.
- Select the corresponding funnel and plunger.

****Equipment needs to be cleaned and sterilized before each procedure.***

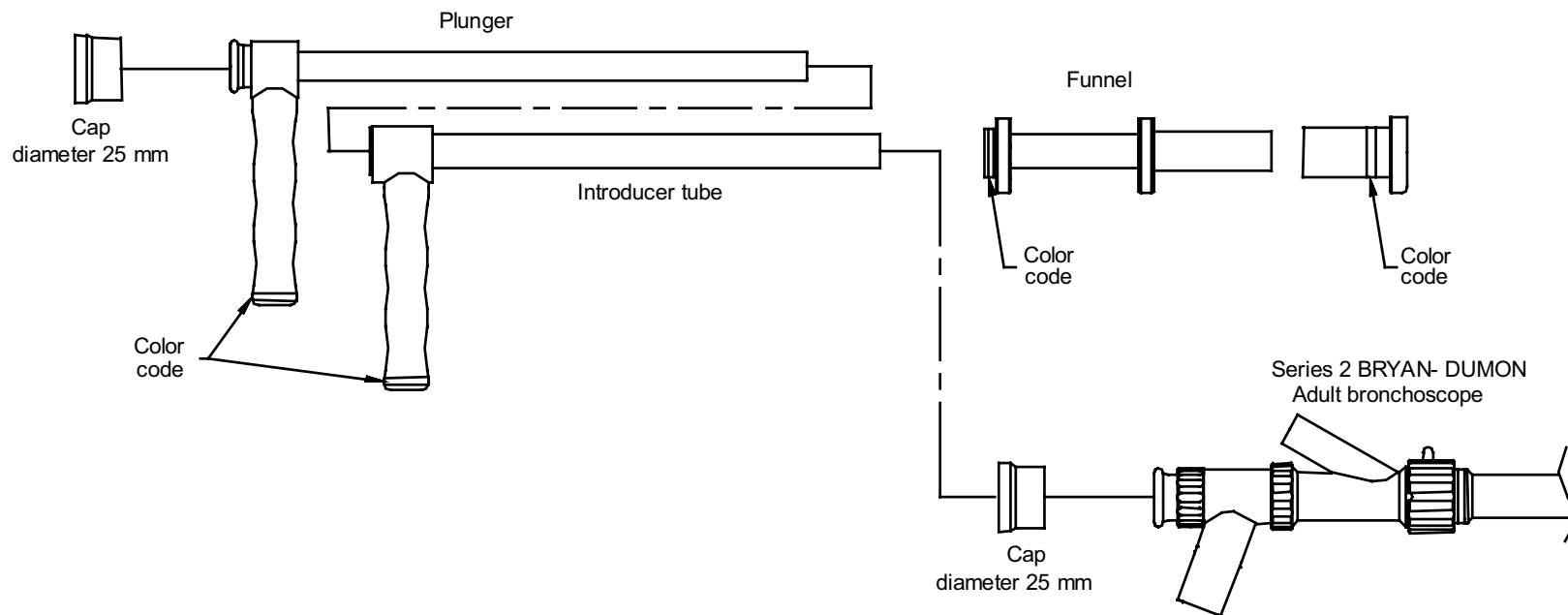

STENT PLACEMENT KIT - LOADING A STENT

- Select the desired size of your silicone stent and have it sterilized.

(Please note that silicone stents are sold non-sterile and they need to be sterilized before each use. Dumon style silicone stents can be sterilized by following the general instrumentation guidelines in this manual, autoclaved at 134°C/ 273°F) See Page 19

- Pick up the stent funnel (two pieces) and remove the cap. Place the funnel on a flat surface with the round tube opening facing up.
- Lubricate the stent with medical grade silicone or other appropriate lubricant. Take the lubricated silicone stent and fold it lengthwise. Feed the folded stent into the stent funnel.



STENT PLACEMENT KIT - LOADING A STENT (CONT.)

- Remove the stent plunger from the stent introducer tube and lubricate the tip and inside the barrel of the stent introducer tube with medical grade silicone or other appropriate lubricant. Take the stent introducer in one hand and the stent funnel in the other.
- Insert the stent introducer tube into the stent funnel and push until you feel a slight resistance and hear a click from the stent introducer tube tip touching the bottom of the stent funnel.
- **DO NOT push using the handle as you may bend the tube. Instead, hold the top part of the introducer tube where the hole is, against your hand.**
- Remove the stent introducer tube from the funnel. Insert the stent plunger into the stent introducer tube. **DO NOT push all the way or you will deploy the stent.**
- The stent is now ready to be deployed.

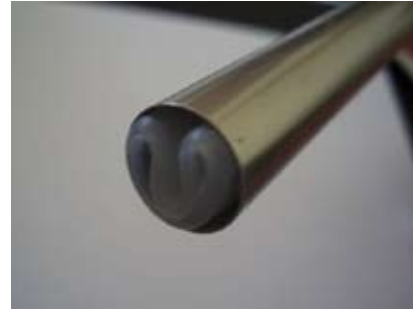

STENT PLACEMENT KIT - DEPLOYING A STENT

- To deploy the stent, remove the telescope from the bronchoscope together with the silicone cap that covers the metallic obturator cap (if used).
- Insert the stent introducer into the bronchoscope tube all the way to the end. It is possible to view the stent deployment by inserting the telescope into the stent plunger. (If desired, you may use a silicone cap on the metallic obturator as well as the stent plunger to prevent air leaks).
- To deploy the stent, push the stent plunger all the way down the stent introducer using a firm, smooth motion. The stent will slide into the airway.
- Remove the telescope from the stent plunger and remove the stent placement system from the bronchoscope. Insert the telescope back into the bronchoscope (with silicone cap, if needed) and manipulate the stent with forceps, if necessary.



Y-STENT - LOADING AND DEPLOYING

- The Bryan-Dumon™ Y-stent loader is compatible with the Bryan-Dumon™ Series II orange and yellow stent placement kits.
- The Y-stent loader is designed to accommodate Dumon Style Y-shaped and straight stents up to 22 mm in diameter. The loader is autoclavable at 134°C/ 273°F cycle.

****Equipment needs to be cleaned and sterilized before each procedure.***



Y-STENT - LOADING

- The Y-stent loader has three pieces: stent funnel, lid and rod.
- Remove the lid and rod from the loader. Generously lubricate the entire groove of the stent funnel with medical grade silicone or other appropriate lubricant.
- Make sure the lubricant coats the inside of the conical metal piece on the end of the stent funnel.
- Have your sterilized or disinfected stent ready. Lubricate the stent over the long-studded portion.



Y-STENT - LOADING (CONT.)

- Fold the stent into a U-Shape and insert it gradually into the groove. The studded (anterior) side of the stent should face up, while the smooth (posterior) side faces down.
- When loading the Y-stent, be sure to insert the tracheal part of the stent facing the conical metal piece of the stent funnel. The correct orientation of the stent is shown on the lid.
- Keep folding the stent until it is completely in the groove of the stent funnel.

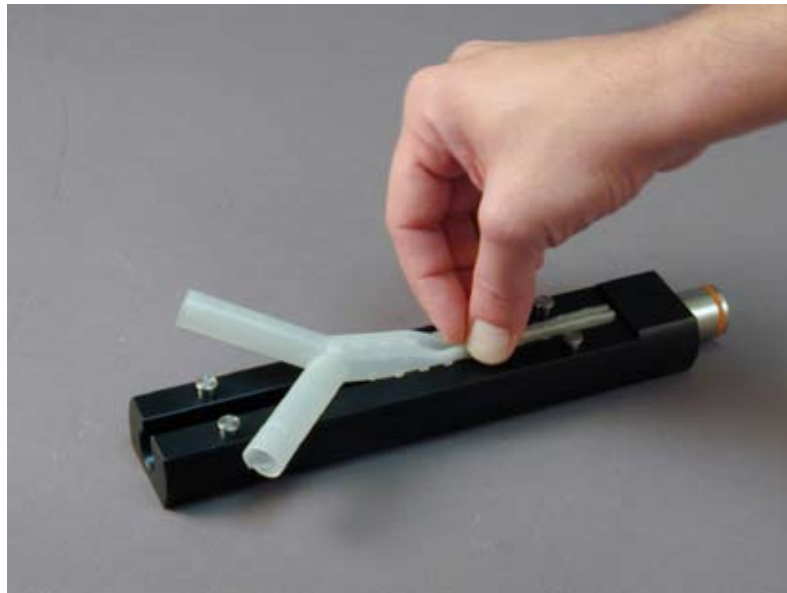

Y-STENT - LOADING (CONT.)

- Place the lid on the stent funnel and slide it into the locked position. Please note the lid only locks one way. Once the lid is in the locked position, the stent is secure.
- Take either the orange or yellow Bryan-Dumon™ stent introducer tube and lubricate the inside generously as this allows the stent to slide smoothly from the stent funnel into the stent introducer.
- Place stent introducer tube onto a flat surface so that the opening of the tube faces up.

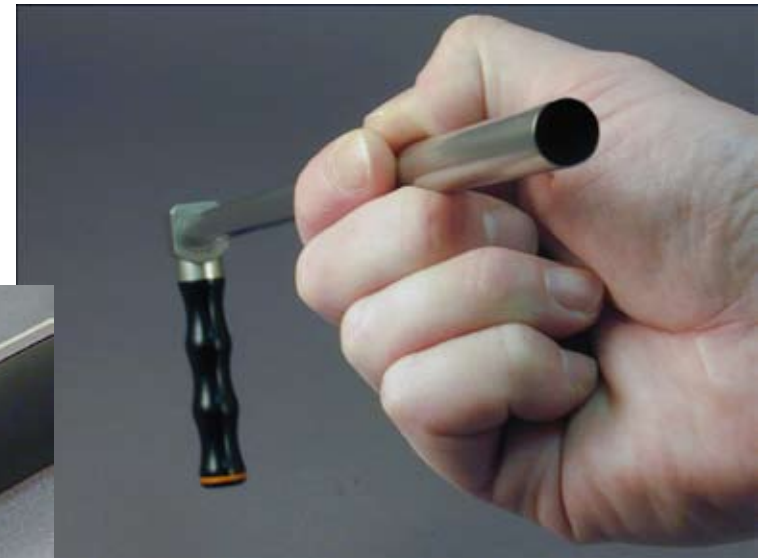
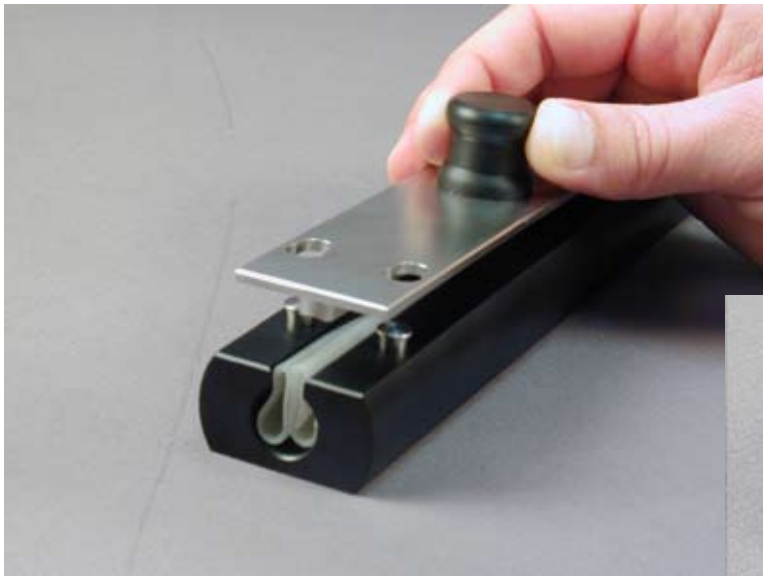

Y-STENT - LOADING (CONT.)

- Insert the metal end of the stent funnel into the stent introducer tube.
- Orientate the stent loader so that the markings on the lid and the introducer tube are in line. This ensures the stent will remain in the correct position.
- Introduce the rod into the open end of the stent funnel. With one hand, hold the stent at the metal end and the stent introducer tube while holding the rod in the other hand.
- With a pumping action, progressively push the rod down and push the stent into the introducer tube. Using the pumping action you will feel the stent slide smoothly from the funnel into the introducer.
- If you feel resistance, stop pushing and allow the stent to reposition itself.
- Continue pushing the stent with the pumping action until the stent is completely inserted into the stent introducer.

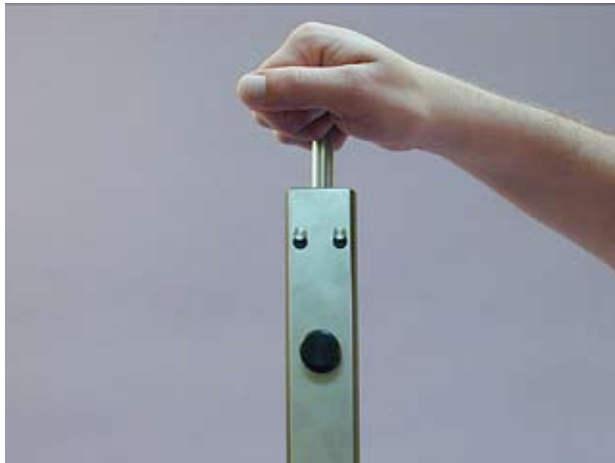

Y-STENT - DEPLOYMENT

- Once the stent is in the introducer tube, remove the stent loader and insert a stent plunger into the stent introducer.
- Before deploying the stent through the rigid bronchoscope, rotate the introducer tube so the marking faces up. This way the stent will deploy into the right position.



BASIC CLEANING AND DISINFECTION OF THE BRONCHOSCOPE

- Disassemble all of the components from the bronchoscope including the metallic obturator caps attached to the universal barrel.
- Use a cotton tip applicator, a soft cloth or a brush to clean the bronchoscope's housing. Rinse with distilled, tap, or de-mineralized water. Dry thoroughly with a soft cloth or compressed air.
- Bronchoscope components are autoclavable at 134 degrees Celsius/ 273 degrees Fahrenheit.

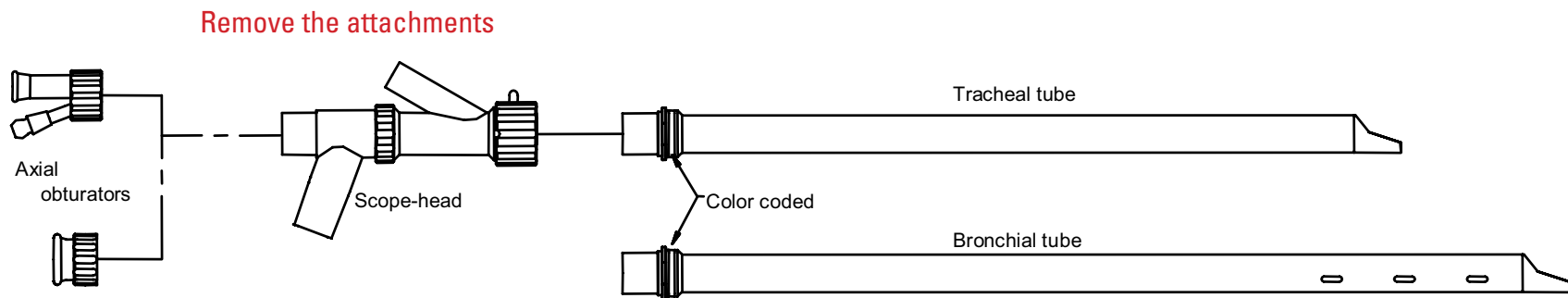

NOTE: When using equipment from other manufacturers in conjunction with Bryan Corporation materials, please refer to the manufacturers instructions for care and maintenance.

CLEANING AND DISINFECTION OF THE TELESCOPE

- Bryan Telescopes MAY NOT be cleaned using ultrasonic.

MANUAL CLEANING:

- The telescope should be cleaned immediately after use, with careful attention paid to blood, secretions and other residues. If immediate cleaning is not possible, the telescope should be immersed in a combined cleaning and disinfection solution.
- Removable parts, such as light guide connectors and adapters, should be cleaned separately. Stopcocks should be in the open position.
- When immersing the telescope or instrument in the disinfecting / cleaning solution, make sure all bubbles escape any cavities by rotating or tipping the device. This will ensure that all surfaces are moistened.
- Encrusted material has to be removed carefully, preferably with plastic brushes and soft cloths. Never use sharp instruments to remove debris. This could scratch the endoscope, particularly the glass components.
- Clean the distal and proximal windows, as well as the light post, with a cotton swab (wooden applicators only) moistened in isopropyl alcohol (70 %) or acetone. As an alternative, a neutral detergent (such as hand soap) can be used.
- Thoroughly rinse the telescope with de-mineralized water and dry it with a soft cloth or compressed air.

MACHINE CLEANING

- Only thermal-neutral processes should be used and they must work in a pH-neutral environment.
- The temperature should not exceed 93° C/199° F. The machine must be equipped with fixtures securing the instruments so they are not damaged during the washing cycle.
- All instruments and scopes need to be removed from machine after cleaning.



GAS STERILIZATION

Endoscopes must be processed according to the hospital's specific regulations for gas-sterilization. Each instrument should be packed in appropriate packaging. The following sterilization method has been validated.

Please follow the manufacturer's instructions.

Ethylene Oxide Sterilization Process

DMB-Sterivit-Automatic

Half-Cycle-Process

Gas: 6 % Ethylene Oxide, 94 % Carbon Dioxide

Chamber pressure: 1.7 bar

Temperature : 55 degrees Celsius / 131 degrees Fahrenheit

Sterilization Time: 60 minutes

Packaging: Standard sterilization bags made of paper laminate (Steriking brand)

(Sterilizer: DMB-Sterivit-Automatic, type 30010 VS, version 908.01a, DMB Aparatebau, volume 300)

After sterilization, the endoscopes need to be aerated at room temperature (approximately 20 degrees Celsius / 68 degrees Fahrenheit) for a minimum of 24 hours. Increasing the temperature shortens the aeration time.



STEAM STERILIZATION

Endoscopes must be processed according to the hospital's specific regulations for steam-sterilization. Only scopes marked "Autoclave" can be autoclaved without restriction. The following sterilization method has been validated.

Please follow the manufacturer's instructions.

Gravity Vacuum Process

Half-Cycle-Process

Parameters: 134 degrees Celsius / 273 degrees Fahrenheit

Sterilization time: 5 minutes

Packaging in metal containers and sterilization bags made of paper laminate (type Steriking)

After sterilization and prior to opening the packaging, let the instruments cool at room temperature. Accelerating the cooling process puts stress on the endoscope, which can cause damage and shorten its working life.



CONTACT INFORMATION

If you have any questions or for more information on Bryan Corporation products and services, please contact us through one of the methods below.

Customer Service: 800-343-7711

E-mail: sales@bryancorp.com

Website: www.bryancorp.com

WE APPRECIATE YOUR BUSINESS!

